

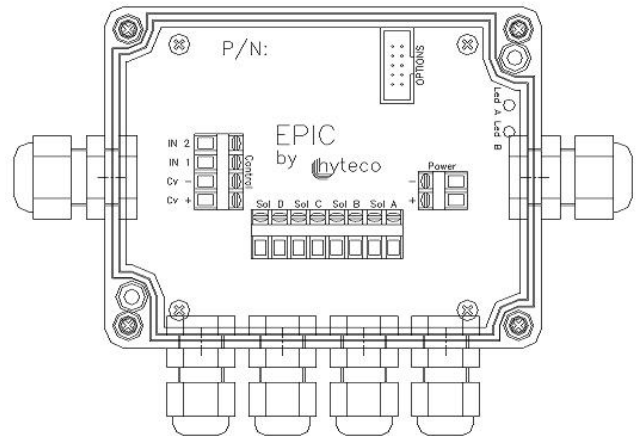

...EXCELLENCE IN FLUID POWER TECHNOLOGY

**EPIC-1000  
Electronic  
Proportional  
Integrated  
Controller**



Technical Data Sheet	EPIC Digital Controller for Proportional Hydraulic Coils
Enclosure Rating	IP 67 (Depending on cable installation)
Power Supply	10 to 30 Volts DC Peak 48 Volts DC < 20ms Reverse Voltage Protected
Control Voltage Output	5, 10 or 15 Volts. Overload protected. (CV)
Inputs (In 1. and In 2.)	+/- 5 Volts 0 to 20 mA 4 to 20 mA Ratio Metric (as a % of supply voltage) Guard Band Limits Adjustable Deadband adjustable
Proportional Outputs (Sol A,B,C and D)	PWM Output with Current Feedback Min Current - .05 Amps to Max Current Max Current – 0.1Amps to 3.6 Amps (Adjustable from Tuner)
Dither	Frequency – 50 to 200Hz Depth - 0 to 25%
Ramps	Ramp Up - each proportional coil Time – 0 to 10 sec. Ramp Down - each proportional coil Time – 0 to 10 sec.
Switched Outputs (Sol A,B,C and D)	Maximum Current – 4 Amps Current Overload Shut Down
Linearity	< +/- 1%

Repeatability	< 1%
<b>Features and Benefits</b>	<b>EPIC - OPTIONS</b>
<ol style="list-style-type: none"> <li>1. The EPIC Driver is designed to take a supply voltage between 10 to 30 volts.</li> <li>2. The enclosure is rated to IP 67</li> <li>3. This product has been designed to meet the European electromagnetic compatibility standards.</li> <li>4. The epic construction gives a high resistance to vibration for mobile use.</li> <li>5. Self diagnostics are completely taken care of with protection for over current, open circuit and short circuit conditions.</li> <li>6. A range of regulated voltages are available on board to supply various input devices such as joystick or pressure transducers.</li> <li>7. Separate glands for each cable are provided with two terminals for each coil to maintain sealing integrity.</li> <li>8. Efficiency and versatility through the use of the latest microprocessor technology.</li> <li>9. Simple adjustments are made for the following by use of the EPIC Tuner <ol style="list-style-type: none"> <li>a. Minimum current</li> <li>b. Maximum current</li> <li>c. Individual ramps on increase and decrease for each channel</li> <li>d. Exclusive to the EPIC is progressive gain</li> <li>e. Built in Dither</li> </ol> </li> </ol>	<p style="text-align: center;">Options</p> <ul style="list-style-type: none"> <li>• RS 232 connection.</li> <li>• CAN BUS technology (Future)</li> <li>• Remote control panel</li> <li>• Remote tuning capability allowing the commissioning to be carried out from the ideal position to observe the machine</li> <li>• Opto isolated 4 to 20mA with reporting back to controls</li> </ul> <p>The technique of measuring feedback current is carried out in this device as well as measuring the voltage. This allows accurate monitoring of the coil condition.</p> <p>This product has been designed to give simple low cost control of any proportional valve.</p> <p>The EPIC controller comes in 4 simple models</p> <ul style="list-style-type: none"> <li>• EPIC – 1000 takes two switched inputs to drive two proportional coils and two solenoid auxiliary coils.</li> <li>• EPIC – 2000 is designed for a single analog input to drive up to two proportional coils and two solenoid auxiliary coils.</li> <li>• EPIC – 3000 has dual analog inputs with four proportional coils. This unit is ideally suited to a dual access joystick control. With the added feature of progressive gain it is easy to obtain smooth control of any machine.</li> <li>• EPIC – 4000 brings closed loop control into the price range of most applications. This compact control features full PID adjustments and is ideal for accurate control of your machine.</li> </ul> <p>The 4000 has a high speed comparator that compares the two inputs and gives the error to the PID loop for an accurate closed loop control, (Patent Pending). This simple but highly effective method brings closed loop control into a new price bracket that any application can afford.</p>

# Typical Circuits

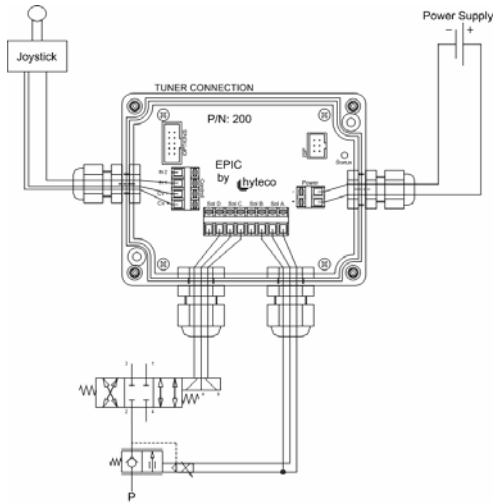

Single Axis With Proportional Flow Control

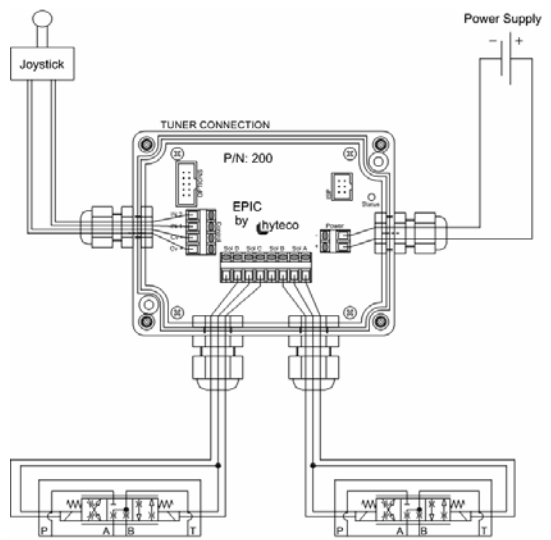

Dual Axis Joystick

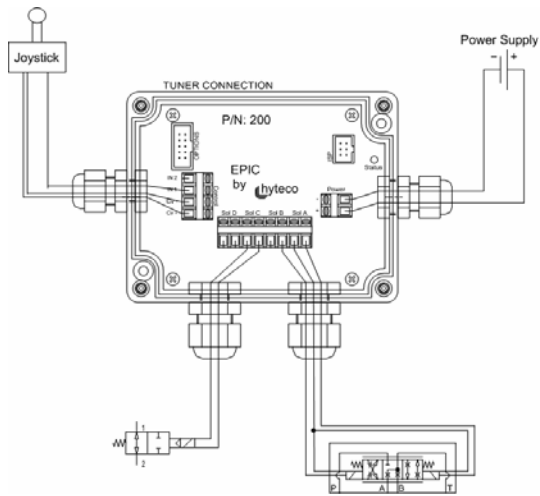

Single Axis With Function Solenoid

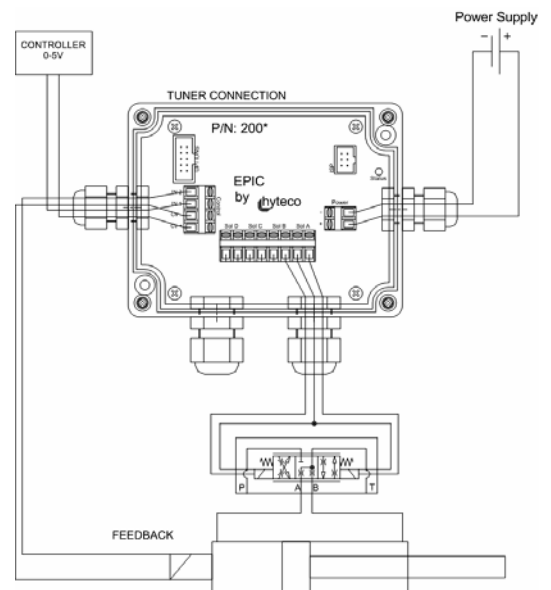

Closed Loop Control